

Novel Maximum Power Point Tracking Control System for Thermoelectric Generator and Evaluation of Mismatch Power Loss Reduction

H. Nagayoshi¹, K. Tokumisu¹, T. Kajikawa²

¹Tokyo National College of Technology, 1220-2, Kunugida-machi, Hachioji, Tokyo, Japan

²Shonan Institute of Technology, 1-1-25, Nishikaigan, Tsujido, Fujisawa, Kanagawa, Japan

Phone: +81-466-68-5392, E-mail; nagayosi@tokyo-ct.ac.jp

Abstract

This paper describes the evaluation result of mismatch power loss reduction using maximum power point tracking (MPPT) power conditioner and their novel MPPT control method. The simulation results suggest that MPPT power conditioner effectively reduce mismatch power loss when each string placed along isothermal line of heat source. The practical power conditioner unit with novel MPPT control method for thermoelectric generator (TEG) systems has been developed. The power conditioner, which is composed of Buck-Boost converter, internal power supply, and microcontroller, is designed for string power conditioner systems. The microcontroller controls the virtual conductance of the load to match the internal conductance of the connected thermoelectric modules. The effect of MPPT power conditioner insertion is evaluated using the experimental TEG system, which composed of four thermoelectric module (TEM) strings. We confirmed each MPPT power conditioner connected in parallel maintains optimum operating condition. The results suggest that introducing MPPT power conditioner has a potential to reduce mismatch power loss effectively and improve load matching ability of TEG systems.

Introduction

Impedance matching between TEG and load is a basic concept in the design of TEG systems. When the TEG system is composed of single TEM with stable heat source and the load, the system design is simple. However, almost heat sources have temperature distribution, causing mismatch power loss of TEG systems. In large TEG systems, thermoelectric modules are connected in series to obtain required output voltage of the load, composing the string. Each string is connected in parallel to obtain required output power. It is impossible to avoid mismatch power loss using simple electrical connection of TEMs when the heat source has large temperature distribution. The mismatch power loss increases with temperature distribution of heat source, much depending on the connection topology of TEMs. Our simulation result suggested the mismatch power loss could be reduced when each string is placed along the isothermal line of the heat source. An MPPT power conditioner is also needed in the systems which have unstable heat source and loads. The insertion of power conditioner, which has impedance matching ability between TEM string and a load, effectively minimizes the mismatch power loss when each string is placed along the isothermal line.

The conventional MPPT control methods used in the photovoltaic systems, calculating the output power to obtain optimum operation point, does not match TEG systems since

the output power of TEG as a function of output voltage shows broad peak. We have developed the new concept MPPT control method suitable for TEG systems.[2] The DC-DC converter inserted between TEG and a load, works as a conductance converter, controlling the virtual load conductance to match the internal conductance of the TEG. The small size power MPPT conditioner for TEM string has been developed. The performance of MPPT conditioner is evaluated using test TEG system composed of four TEM strings. The TEG system performance with and without MPPT power conditioner has investigated.

Mismatch Power Loss in TEG Systems

TEMs should be connected in parallel and series in large TEG systems. When TEG is composed of different output TEMs, the system has mismatch power loss. Figure1(a) shows the mismatch power loss in parallel connection. In the parallel connection of TEMs, each TEM is operating at the same output voltage. Temperature distribution of heat source causes a deviation from the optimum operation voltage of the TEM. If V_{oc} of the TEM in parallel connection is lower than the synthesized operating voltage, reverse current flows in the TEM. That means the TEM works as a load. Figure 1(b) shows the mismatch power loss in series connection. In the series connection of TEMs, each TEM is operating at the same current. Since each module is operating at the common current, temperature distribution causes the deviation from the optimum operating current. When short circuit current of TEM in the string is lower than the string current, the TEM works as a load.

An insertion of power conditioner with MPPT control between TEG and load effectively reduce the mismatch power loss. Figure2 shows the possible TEG systems with power conditioners. The single MPPT converter system is effective when temperature distribution is small. In the module MPPT converter system, each module maintains ideal operation point. The effect of mismatch power loss reduction by string converter systems much depends on the connection topology except module converter system. If the cost of power conditioner is reasonable, this will be an ultimate system. In terms of cost and MPPT effect, string converter system is most practical.

MPPT Control Method with Virtual Conductance Control

When the internal conductance of TEG coincides with the load conductance, generating power in the TEG can be derived without any mismatch loss. The output voltage at maximum power operation point is half of the open circuit

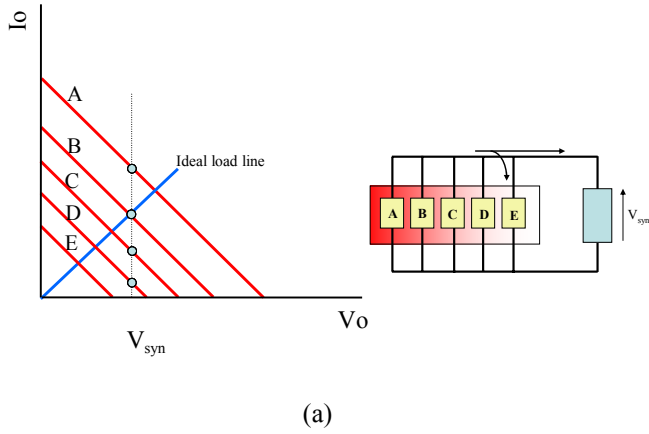

(a)

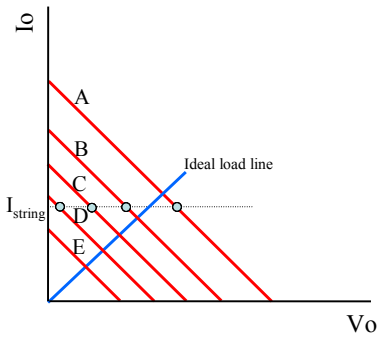

(b)

Fig.1 Mismatch power loss caused by temperature distribution in parallel and series connection.

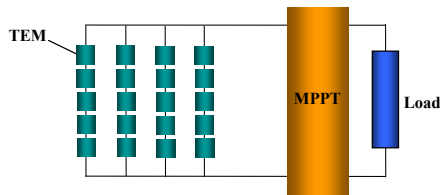

(a)

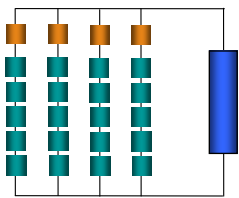

(b)

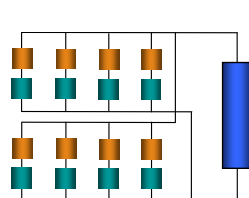

(c)

Fig.2 TEG system with power conditioner: (a) single converter (b)string converter (c) module converter.

voltage (V_{oc}). The DC-DC converter could control voltage conversion ratio, meaning the converter could control the virtual load conductance. If the virtual load conductance is

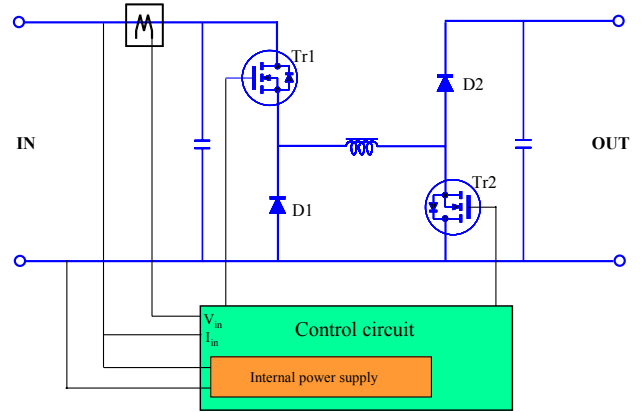

Fig.3 Schematic of the MPPT power conditioner circuit.

controlled to match the value of internal conductance of the TEM, the operation point of the TEM maintains the optimum condition. A step up converter could control the virtual conductance toward higher value than the load. On the other hand, step down converter enables to control the virtual conductance to the lower value. Hence, the DC-DC converter needs the Buck-Boost circuit, which has an ability of step up/down conversion of the voltage, to achieve wide matching ability. It was experimentally confirmed that the deviation of internal conductance by change of temperature difference could be negligible.[2] The schematic the MPPT power conditioner circuit is shown in Fig.3. In the step down mode, Tr2 maintains off and Tr1 is driven as PWM switching. On the other hand, in the step up mode, Tr2 maintains on while Tr1 is driven as PWM switching. At the continuous current mode, the conversion ratio of converter is expressed as

$$V_o/V_{in} = \begin{cases} (T_{on} + T_{off})/T_{off} & \text{(Step up mode)} \\ T_{on}/(T_{on} + T_{off}) & \text{(Step down mode)} \end{cases} \quad (1)$$

Where T_{on} and T_{off} are the time of on and off period of the switching transistor, respectively. This suggests the voltage conversion ratio of the MPPT conditioner could be widely changed by introducing Buck-Boost circuit. Maximum duty ratio of the step up mode is limited by the limit of maximum applying voltage on D2, Tr2, and output capacitor. The virtual load conductance could be obtained by measuring input current and voltage of the DC-DC converter during the MPPT operation. On the other hand, internal conductance of the TEG should be measured prior to the feedback control. The internal conductance could be calculated by measuring short circuit current and open circuit voltage. However, internal power supply in the control system became unstable during the short circuit current measuring period since the electric power of the controller is supplied from the TEG. In this circuit, the internal conductance of the TEG is measured at the operation point of $1/2 V_{oc}$. When the load conductance is lower than the internal value of the TEG, initial operation point should be shifted to the point of $1/2 V_{oc}$ using step up mode. In case of the load

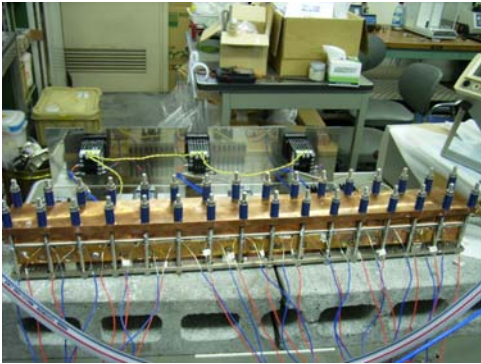

Fig.4 Experimental TEG system.

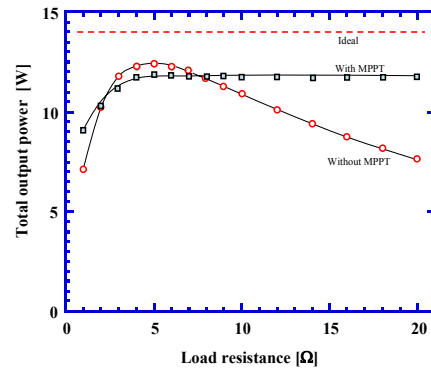

Fig.7 Output power as a function of load resistance.

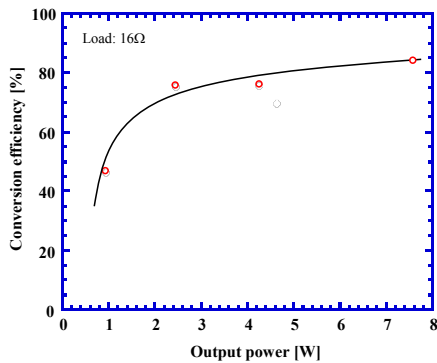

Fig.5 Conversion efficiency of the power conditioner as a function of output power.

conductance is higher than the internal value of TEG, operation point is shifted by the step down mode. The initial operation mode of the Buck-Boost converter is decided by the initial output voltage of the TEG when the load is connected without PWM switching. After the internal conductance measurement, feedback control starts.

Experimental and Results

The practical MPPT conditioner for TEM string with the size of $30 \times 60 \text{ mm}^2$, which can be used up to 30W, has been developed. The circuit works when the input voltage is higher than 2V using the internal switching power supply. The energy consumption of the control circuit is quite low and could be negligible ($<10\text{mW}$). The conversion efficiency of power conditioner is shown in Fig.5. The conversion efficiency increases with conversion power, saturating at 84.5% with step up mode. Present conversion efficiency does not enough, however higher efficiency could be expected by introducing synchronized switching technique.

The electrical connection topology of the test TEG system is shown in Fig.6. Each string is composed of five TEMs of same temperature difference. The output property of the TEG system with and without MPPT power conditioner is compared. Figure 7 shows the output power as a function of load resistance. The ideal line shows the sum of maximum power of each string. As our previous report suggests, maximum power of the TEG shows lower value than the ideal maximum power even when there is no internal temperature distribution in the string. Each string has optimum operation voltage, but deviates from the ideal output voltage when each string is connected in parallel. The maximum power of TEG appears when the load is 5Ω , being coincides with the synthesized internal resistance of the TEG. We confirmed that each MPPT power conditioner connected in parallel as shown in Fig.6(b) operates normally. The output voltage and current of each string output maintains constant value in spite of load change. When the load resistance is higher than 5Ω , the MPPT power conditioner is operating with step up mode. In this mode, output power is almost constant in spite of load change. The insertion of power conditioner reduces the mismatch power loss when the load resistance is higher than

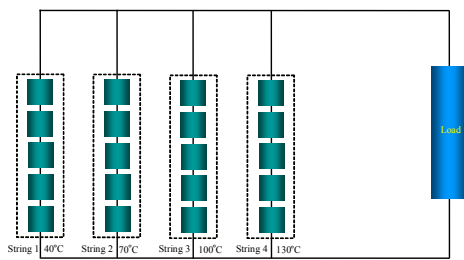

(a)

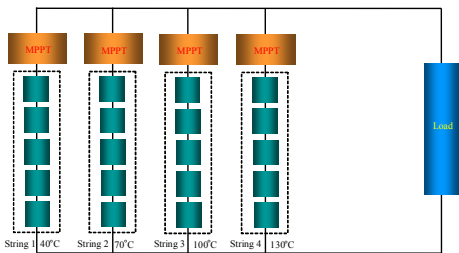

(b)

Fig.6 Electric connection of the test TEG system: (a) without MPPT power conditioner, and (b) with MPPT power conditioner.

7Ω. On the other hand, output power with MPPT decreased with decrease

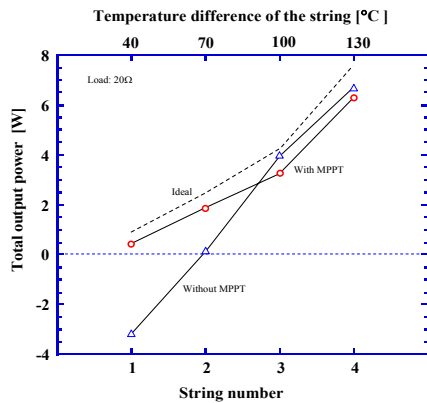

(a)

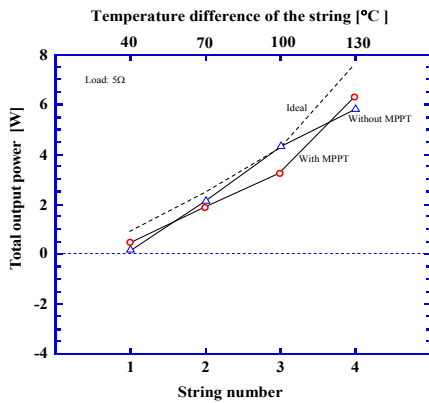

(b)

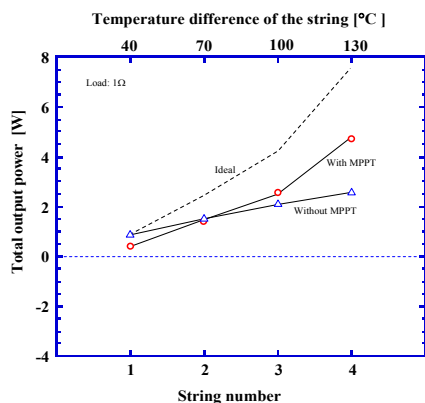

(c)

Fig.8 Output power of each string on different load conditions: (a) 20Ω, (b) 5Ω, and (c) 1Ω.

of the load resistance at step down mode. The D2 become hot in this condition. When the load resistance is low, the circuit

of step down mode outputs large output current through D2, leading energy loss in D2. An introducing synchronized switching circuit, which uses low on resistance MOSFETs instead of switching diodes in Fig.1, could reduce such conversion energy loss. We are now preparing the next generation high efficiency type circuit. Fig.8 shows the output power of each string. When the load resistance is 20Ω as shown in Fig.9(a), low temperature string does not contribute the output power. This means that operating voltage of TEG is higher than the open circuit voltage of low temperature string. The string NO.1 indicates negative power, suggesting the lowest temperature string works as a load, leading large internal power loss. On the other hand, low temperature strings contribute output power when the MPPT power conditioners are used. Fig.8(b) shows the result when the load resistance is 5Ω. In this condition, string NO.3 is operating near the optimum condition. So, inserted power conditioner simply leads power loss. On the other hand string NO.4 deviates from the optimum operating point, showing large mismatch power loss. The figure indicated that insertion of MPPT power conditioner is recovering the mismatch power loss. Figure8 (c) shows the result when the load resistance is 1Ω. The output power of lowest temperature string matches the ideal value. On the other hand, the strings of higher temperature difference show large mismatch power loss. In this condition, the circuit is operating with step down mode and energy conversion efficiency is lower than step up mode by the energy consumption of D2. In spite of low conversion efficiency, MPPT converter insertion recovers the mismatch power loss of high temperature strings. From these results, we confirmed the TEG system shows wide matching ability by introducing MPPT conditioner. If conversion efficiency of the circuit is much improved, there is a large merit of introducing MPPT power conditioner.

Summary

The practical maximum power point tracking conditioner for TEM string has been developed. The parallel connection of TEM strings through MPPT power conditioner is evaluated. We confirmed each MPPT power conditioner maintains the optimum operating condition of TEM string even when MPPT converter outputs are connected in parallel. The decrease of conversion efficiency at step down mode is observed. The results are suggests that when conversion efficiency of the circuit is much improved by introducing synchronized switching circuit, there is a large merit of introducing MPPT power conditioner.

References

1. H. Nagayoshi, and T. Kajikawa, Proceedings of the 3rd European Conference on Thermoelectrics, (2005)76-79.
2. H. Nagayoshi, and T. Kajikawa, Proceedings of the 25th International Conference on Thermoelectronics, (2006)